

H-MP CONT GRINDER-PRESS



H-MP CONT GRINDER-PRESS

USE

The machine is designed to prepare orgeat "horchata" (a sweet drink made of tiger nuts or almonds). It unifies the processes, grinding, water supply, maceration, the pressing of the pulp and filtering. It is possible to make various batches of the product without stopping the machine. The machine is able to produce **300 litres of "horchata" in 1 hour**.

CONSTRUCTION

The machine is constructed of 18/8 AISI-304 standard stainless steel throughout and incorporates wheels so that it can be moved easily. The most important elements of the machine are:

- One add-on hopper, of easy assembly, for extra capacity.
- A flow meter, to counts the litres of water selected.
- A tank with an impeller with crusher hammers inside. As this piece rotates, the grinding and maceration take place.
- A motor which drives the impeller through a transmission of pulleys and belts.
- A removable filter with a spout through which the tiger nuts or almond "milk" flows.
- A removable hose on the side for easy cleaning.
- A tube with regulating nut which controls the amount of pulp passing through.
- A worm gear in two conical parts, that rotates and pushes the pulp towards the regulating nut, thus squeezing the pulp.
- A gear motor that drives the worm gear.
- A tubular filter around the worm gear.
- Two silicone tubes through which the squeezed juice returns to the tank, for its maceration.

The machine has a control panel in which the PLC and all the control buttons are integrated.

OPERATION

The machine can operate in automatic or manual mode.

Since the cycles are programmable, it is usually used in automatic mode, and one only has to follow the instructions below:

- Pour the tiger nuts or almonds into the hopper.
- On the PLC screen, select the number of litres of water needed to make the tiger nut or almond "milk".
- Press the start button.
- Place a container to collect the tiger nut or almond "milk" and another to collect the pulp.
- Press the stop button when the flow of "milk" ceases.

The manual mode is basically used for cleaning:

- Press the water button.
- Press the extractor start button (pressing worm gear).

In this way the machine will extract any remaining pressed pulp, and so we can dismount the tube and the pressing worm gear for cleaning throughout.

NOTE

The manufacturer reserves the right to make partial or total modifications to the measurements or design of this machine without such changes forming grounds for complaint.

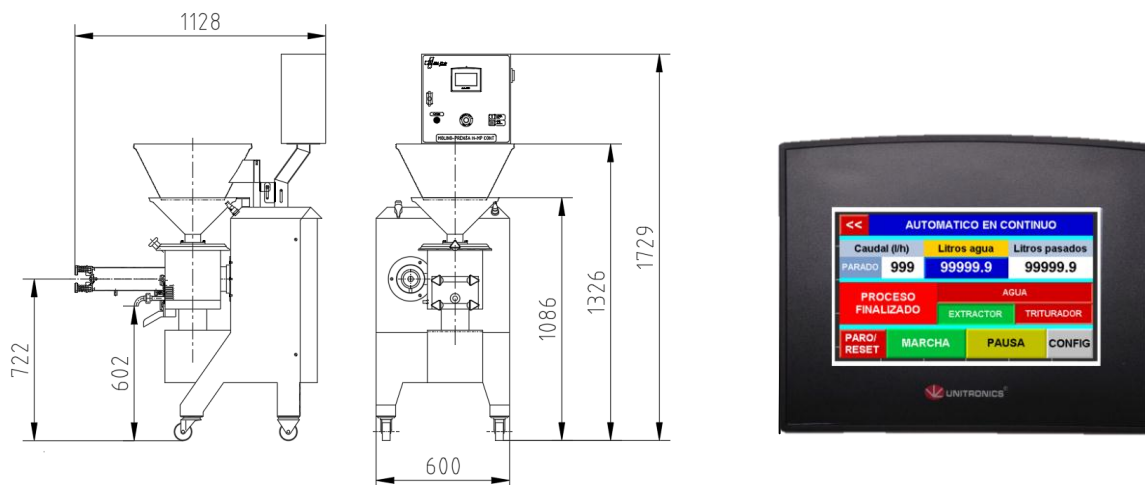

CHARACTERISTICS

MODEL	H-MP CONT
GRINDER POWER (kW)	4
PRESS POWER (kW)	1'5
TOTAL POWER (kW)	5'5
VOLTAGE AT 50 Hz. (Volts)	(230 / 400) 50Hz – 460 60Hz (three-phase)
HOPPER CAPACITY (kg)	25
PRODUCTION (litres / hour)	300 (approximate)
NET WEIGHT (kg)	180

MECÁNICA JIJONENCA, S.A.

MANUFACTURE AND INSTALLATION OF MACHINERY FOR THE FOOD INDUSTRY AND PRESSURE DEVICES
POLIGONO INDUSTRIAL SEGORB, S/N. – TEL. 96 561 05 85 / 96 561 07 82 – FAX. 96 561 06 52

www.mejisa.com – e-mail: info@mejisa.com
03100 JIJONA (ALICANTE)

